

CY65D 單軸 1-axis

螺桿驅動 Ball Screw Drive

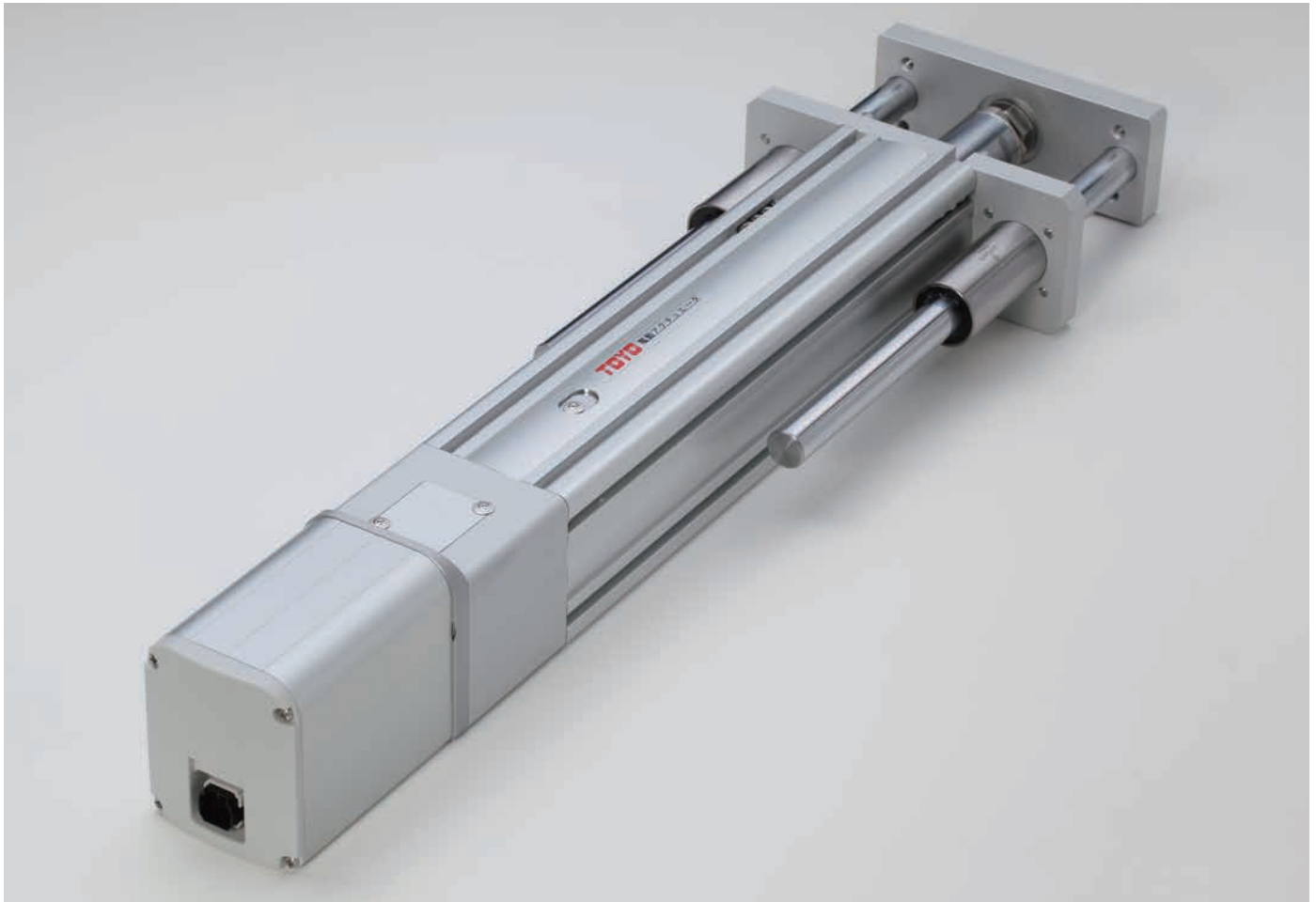

- 最大行程 Maximum Stroke **500mm**
- 最高速度 Maximum Speed **1000mm/s**
- 馬達尺寸 Motor Dimension **56□mm**
- 滾珠螺桿 Ball Screw **∅16mm**
- 導桿軸心 Dia Of Shaft **∅16mm-2pcs**

型號表示方式 Ordering Method

CY65D - L10 - 300 - M - TC100 - 03 - A0001

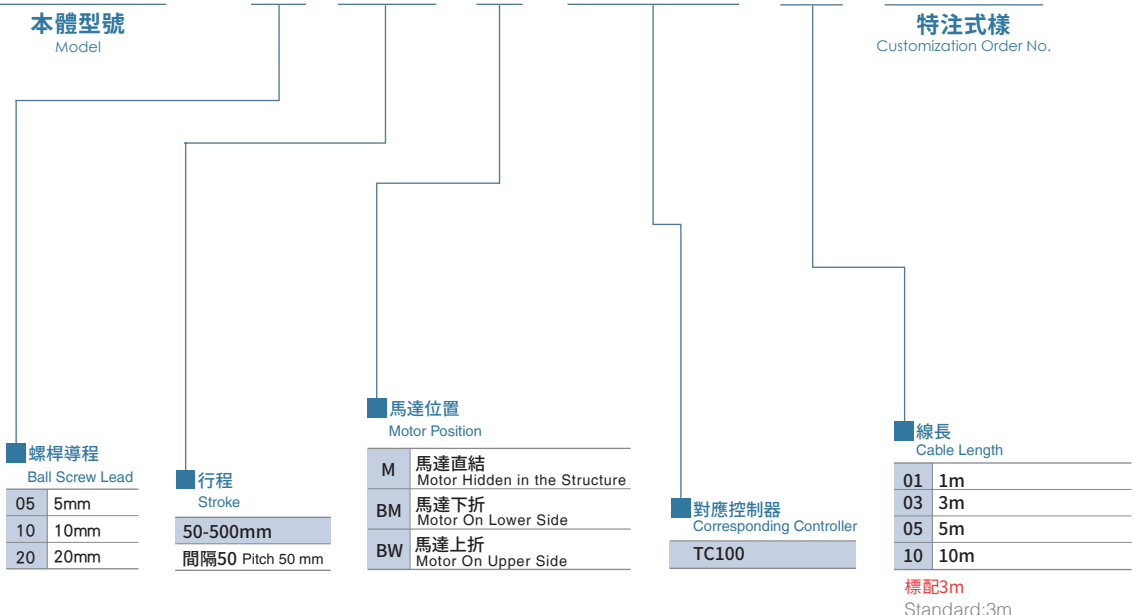

基本仕様 Specification

規格 Spec	位置重複精度 Repeatability (mm)	±0.01			
	螺桿導程 Ball Screw Lead (mm)	5	10	20	
	最高速度 Maximum Speed (mm/s) ※2	≤250	≤500	≤1000	
	最大可搬重量 Maximum Payload	水平使用 Horizontal (kg)	≤110	≤88	≤40
		垂直使用 Vertical (kg)	≤30	≤20	≤10
	定格推力 Rated Thrust (N)	791	395	197	
標準行程 Stroke / Pitch(mm) ※1	50-500 / 50				
部品 Parts	馬達尺寸 Motor Dimension (mm)	56□			
	滾珠螺桿規格 Ball Screw Spec	C7 φ 16mm			

※1 行程超過300mm時，會產生螺桿偏擺震動，此時請將速度調降。詳細請參考P45頁說明。
When the stroke is over 300mm, the run-out of the ballscrew will occur.
We recommend to low down the working speed under this circumstances. Please refer to P45 for details.

※2 此處最高速度為軟體移動速度設定為100%時。
The maximum speed shown here is when software speed setting is 100%.

速度-荷重曲線圖 Speed-Payload Relationship

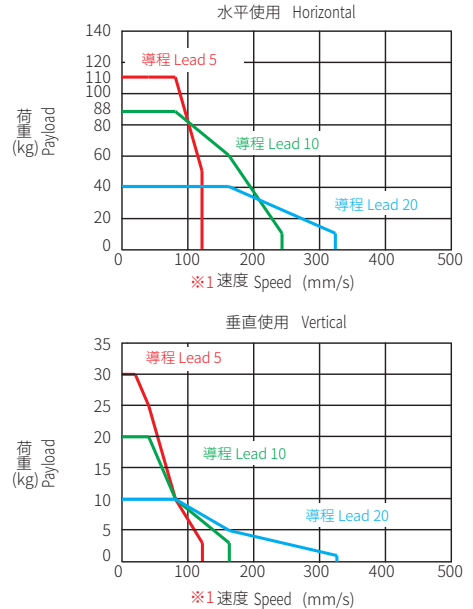

防止迴轉精度 Anti-rotating Accuracy

■ 固定板的防止迴轉精度
Anti-rotating Accuracy of Plate

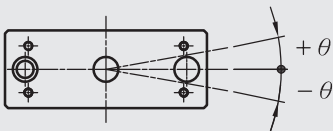

防止迴轉精度 θ
Anti-rotating accuracy
±0.05°

對應控制器一覽表 Corresponding Controller Chart

外觀 Exterior	控制器型號 Controller Model	控制介面 Control Mode	特點 Features	電氣規格 Electrical Spec.	詳細參閱 Reference Page
	TC100	Pulse控制 Pulse Control Mode	Line driver 500k Hz Open collector 200k Hz 同時只能使用一種。 Support Line driver and Open collector Max.pulse receiving speed 500k/200k Hz.	控制電路只能使用24V。 工作電壓DC24V， 額定電流 2A，峰值電流3A。 工作電壓DC48V， 額定電流 1A，峰值電流2A。	P.99
		I/O控制 I/O Control Mode	利用I/O變化，最多可以執行127個 位置控制。 By I/O control, max. 127 positioning points, can be executed.	使用DC48V時在相同扭力下， 轉速會提升，詳細內容請跟服務 窗口連絡。 The voltage of control circuit is 24V only.	
		通訊控制 Communication Control Mode	採Modbus的RS485通訊介面 (最大並接16台)及一組mini USB (TOYO Single專用)。 Use Modbus as the interface of RS485 (connect max. 16 controllers) and 1 set mini USB. (special for TOYO-single)	Operating voltage DC24V, rated current 2A, peak current 3A. Operating voltage DC48V, rated current 1A, peak current 2A. When the voltage is DC48V but same torque, the rotation speed will be raised. Please contact your service window to details.	

CY65D

單軸
1-axis

螺桿驅動 Ball Screw Drive

M 馬達直結 Motor Hidden in the Structure



CAD圖面可至www.toyorobot.com下載
Please download the CAD file from TOYO's website: www.toyorobot.com

(單位 Unit : mm)

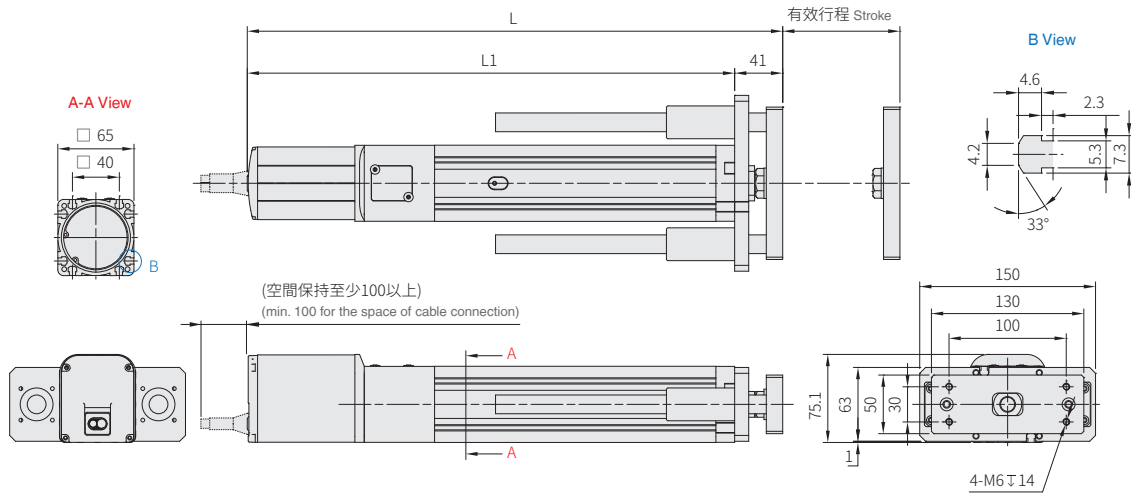

有效行程 Stroke	50	100	150	200	250	300	350	400	450	500
L	407	457	507	557	607	657	707	757	807	857
L1	366	416	466	516	566	616	666	716	766	815
*Weight(kg)	6	6.26	6.52	6.78	7.03	7.29	7.55	7.81	8.07	8.32

*重量包含本體與馬達。 Weight of model with motor.

BW 馬達上折 Motor On Upper Side



CAD圖面可至www.toyorobot.com下載
Please download the CAD file from TOYO's website: www.toyorobot.com

(單位 Unit : mm)

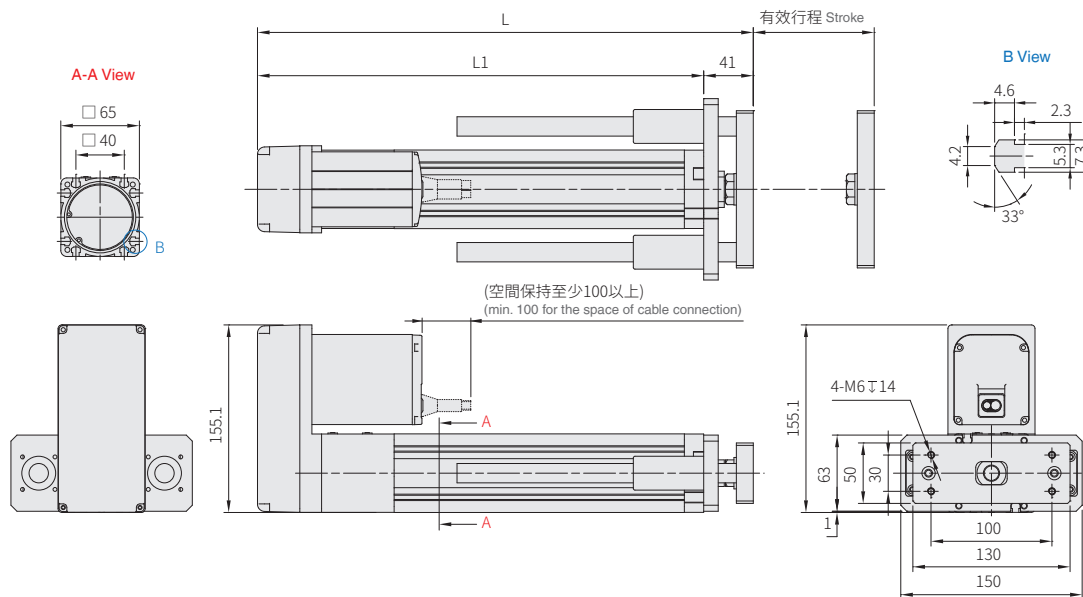

有效行程 Stroke	50	100	150	200	250	300	350	400	450	500
L	360	410	460	510	560	610	660	710	760	810
L1	319	369	419	469	519	569	619	669	719	769
*Weight(kg)	6.5	6.76	7.02	7.28	7.53	7.79	8.05	8.31	8.57	8.82

*重量包含本體與馬達。 Weight of model with motor.

免費服務專線：大陸 400-875-0009 台灣 0800-800-893
Toll-Free Number China Taiwan

BM 馬達下折 Motor On Lower Side



• CAD圖面可至www.toyorobot.com下載 •
Please download the CAD file from TOYO's website: www.toyorobot.com

(單位 Unit : mm)

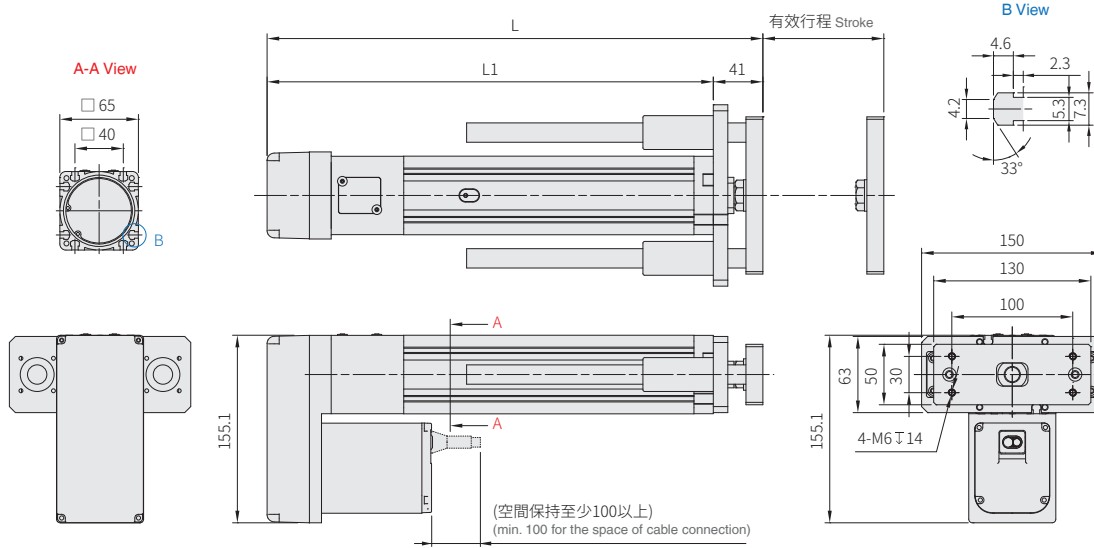

有效行程 Stroke	50	100	150	200	250	300	350	400	450	500
L	360	410	460	510	560	610	660	710	760	810
L1	319	369	419	469	519	569	619	669	719	769
*Weight(kg)	6.5	6.76	7.02	7.28	7.53	7.79	8.05	8.31	8.57	8.82

*重量包含本體與馬達。Weight of model with motor.

特色說明
Feature Description

CTH 系列
Slider Cylinder

CY 系列
Rod Cylinder

CS 系列
Electric miniature cylinder

CH 系列
Electric gripper

控制器規格
Spec. of controller

CY

CY50

CY50D

CY50L

CY65

CY65D

CY65L